



**AUSFÜHRUNGEN:**

Voltage	Output	Luminous flux LED-Panel	Protection Class	Cable with plug	Outlets Sockets	Weight without Cable	Order No.
24 V AC / 50 HZ	29 W	4.200 lm	IP66	5 m 10 m	- ohne -	1,69 kg	<b>QVL2430/5</b> <b>QVL2430/10</b>
			IP44	5 m 10 m	1 CEE 24V 16A, 2 pol.	1,79 kg	<b>QVL2430/5/1</b> <b>QVL2430/10/1</b>
IP66			5 m 10 m	- ohne -	1,69 kg	<b>QVL4230/5</b> <b>QVL4230/10</b>	
IP44			5 m 10 m	1 CEE 42V 16A, 2 pol.	1,79 kg	<b>QVL4230/5/1</b> <b>QVL4230/10/1</b>	
42 V AC / 50 HZ	36 W	5.000 lm	IP66	5 m 10 m	- ohne -	1,92 kg	<b>QVL2330/5</b> <b>QVL2330/10</b>
			IP54	5 m 10 m	3 Schutzkontakt	2,10 kg	<b>QVL2330/5/03</b> <b>QVL2330/10/03</b>

**SPECIAL FEATURES:**

- with sockets like fig. IP44/IP54; without socket IP66
- dimensions in mm:: WxHxD = 305/320/115
- limited weight
- LED panel with highly efficient SMD LEDs
- housing of impact-resistant polycarbonate, covered with soft rubber
- handle of impact-resistant ABS with 6 locking positions for positioning
- with robust switch on the lamp
- low heat development
- SAFETY also when used in wet areas
- limited space required, flat and compact form
- easy and trouble-free handling in practice
- high light output with low energy consumption, COST SAVINGS
- suitable for mobile use on building and construction sites
- simple to transport, can be set up versatily and in all situations
- can be switched on and off directly at the workplace
- no burns when touched, SAFETY

– other cable lengths and other models on request / subject to modification and errors –



Tripod BETA 3

**ACCESSORIES:**

- tripod type BETA 3 with Ø 30 mm DIN pins
- aluminium black
- height when folded 114 cm
- maxium height when set up: 252 cm
- minimum height when set up: 96 cm
- diameter of the maximum footprint: 114 cm
- max. load capacity: ca. 30 kg
- tripod weight of ca. 6,5 kg
- completely preassembled
  
- basic mounting bracket for attaching the support bar with a 30 mm DIN pin
- 1-panel support bar
- 2-panel support bar
- Magnetic mount for 1 piece QVN 72 (2 large magnets with support rail)

Order No.

**TV7521SA**

**TV001**

**QVL029**

**QVL030**

**QVL029M2**



Basic mount TV001

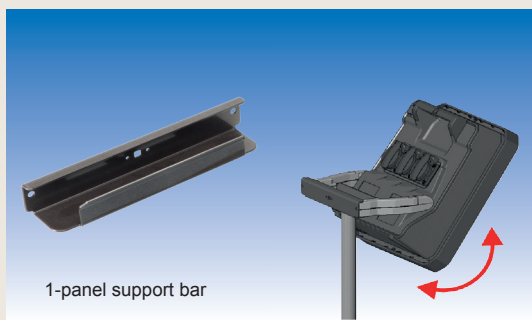

1-panel support bar



2-panel support bar

– other tripods and cross bars are found starting on page 7 / subject to modification and errors –