

**MODELS:**

Voltage	Output	Luminous flux LED-Panel	Protection class	Cable with Plug	Outlets Sockets	Weight without Cable	Order No.
230 V / 50 HZ	29 W	3.100 lm	IP 55	5 m 10 m	- ohne -	1,2 kg	<b>QVL2325/5</b> <b>QVL2325/10</b>
			IP 54	5 m 10 m	2 Schutzkontakt	1,5 kg	<b>QVL2325/5/02</b> <b>QVL2325/10/02</b>

- dimensions (WxHxD): 215 x 250 x 155 mm → limited space required, flat and compact form
- limited weight → easy and trouble-free handling while in use
- LED panel with highly efficient SMD LEDs → high light output with low energy consumption, COST SAVINGS
- housing made of impact-resistant polycarbonate, edge protector of soft, thermoplastic elastomer → strongly suitable for mobile use on building and construction sites
- incl. robust switch on the lamp → can be switched on and off directly at the workplace
- low heat development → no burns when touched, SAFETY

– other cable lengths and models on request / subject to modification and errors –



**ACCESSORIES:**

- Tripod type DELTA 4 with Ø 30 mm DIN pins
- black aluminium
- height when folded: 105 cm
- maximum height when set up: 360 cm
- minimum height when set up: 125 cm
- diameter of the maximum footprint: 110 cm
- max. load capacity: ca. 13 kg
- tripod weight: ca. 2.5 kg
- completely preassembled

Order No.

**TV7731**

- luminaire bracket + U-stand adapter
- luminaire bracket + female spigot adapter

**QVL2210**

**QVL2220**

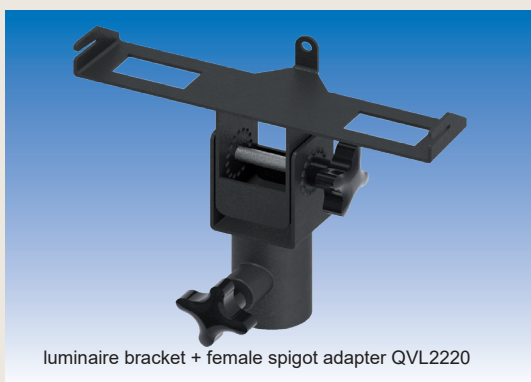
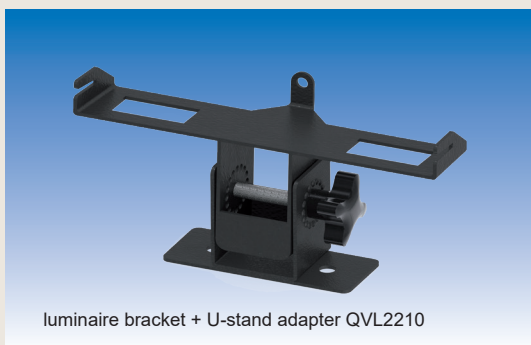

– other tripods and cross bars are found starting on page 13.1 / subject to modification and errors –