

VERSIONS:

Voltage	Power	Luminous flux	Input	Dimensions (L x W x H)	Weight	Order no.
24 V DC*	6 W	600 lm	Built-in appliance connector 4 pol. / 4 A / 24 V DC / M8	190 x 40 x 18 mm	0.3 kg	7ST24S
			5 m ELSPRO-FLEX® G05** 2 x 1.0 mm ²		0.7 kg	7ST24S/5-
	12 W	1,200 lm	Built-in appliance connector 4 pol. / 4 A / 24 V DC / M8	310 x 40 x 18 mm	0.5 kg	7ST24M
			5 m ELSPRO-FLEX® G05** 2 x 1.0 mm ²		0.9 kg	7ST24M/5-
	24 W	2,400 lm	Built-in appliance connector 4 pol. / 4 A / 24 V DC / M8	555 x 40 x 18 mm	0.7 kg	7ST24L
			5 m ELSPRO-FLEX® G05** 2 x 1.0 mm ²		1.10 kg	7ST24L/5-

* other voltages on request
** ELSPRO-FLEX® G05 see page 8.9

FEATURES:

- 32 / 64 / 128 x NICHIA 757 LEDs
 - Colour temperature 5,500 K
 - Beam angle 120
 - Lifetime of at least 50,000 hours
 - Housing made of aluminium (solid material) and front pane made of acrylic glass
 - Direct mounting or mounting by means of magnet sets, either flat or with tilting joints
 - IP 67
 - low overall height of only 18 mm
 - Protection class 3
- high luminous efficacy and uniform light pattern
 - daylight white
 - large beam angle with uniform illumination
 - proven durability
 - high quality and robust, reliable use under extreme conditions
 - easy installation in machines and production lines
 - dustproof and waterproof
 - Easy installation even in very tight spaces and installation locations
 - Protecting personnel at the highest level

- other versions on request / subject to change and error -

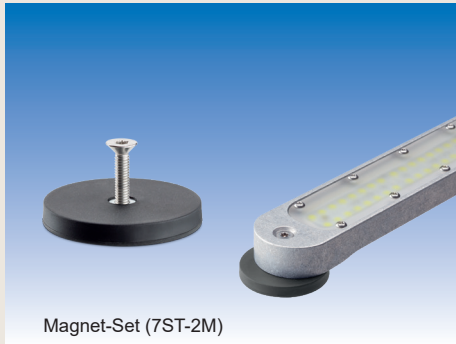

Magnet-Set (7ST-2M)

Accessories

Order no.

- 2 holding magnets
- Ø 43 mm, height 5 mm
 - Adhesive force 10 kg
 - incl. fastening screws
 - Magnet with rubber coating

7ST-2M



Swivelling magnet set (7ST-2M/SB)

- 2 swivelling (90°) holding magnets
- Ø 43 mm, height 27 mm
 - Adhesive force 10 kg
 - incl. fastening screws
 - Magnet with rubber coating

7ST-2M/SB

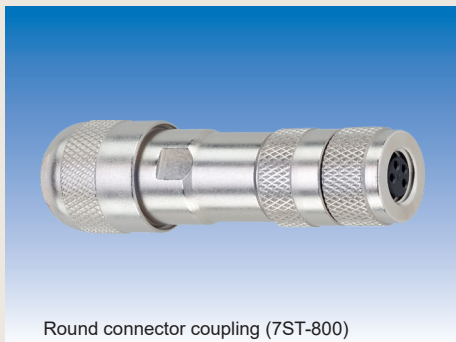

Round connector coupling (7ST-800)

- Round connector coupling
- 4 pole / 4 A / 24 V / M8 / IP 67
 - Flexible wire gauge 1.00 mm²
 - Screw terminal connection
 - for a cable diameter of 6.0 - 8.0 mm
 - CuZn brass housing material
 - Material contact pins: Brass, gold plated
 - Temperature resistance -40° / + 85° °C
 - IP 67 protection class

7ST-800

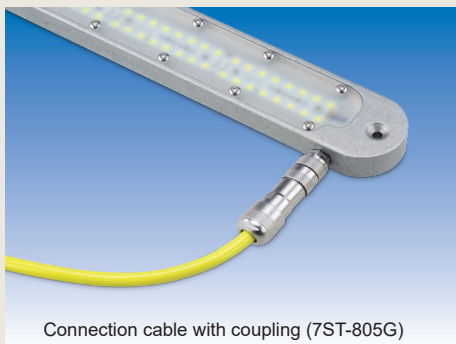

Connection cable with coupling (7ST-805G)

- Pre-assembled device connection cable consisting of:
- 5 m ELSPRO-FLEX® G05 2x1,0
 - Yellow signal colour
 - highly flexible special hose line with modified polyurethane jacket and copper class 6
 - 25 mm open cable end stripped and fitted with wire end ferrules
 - 1 Round connector coupling
- 4 pole / 4 A / 24 V / M8 / IP 67
- PIN 1 L
 - PIN 4 N
 - for a cable diameter of 6.0 - 8.0 mm

7ST-805G

DIMENSIONS:

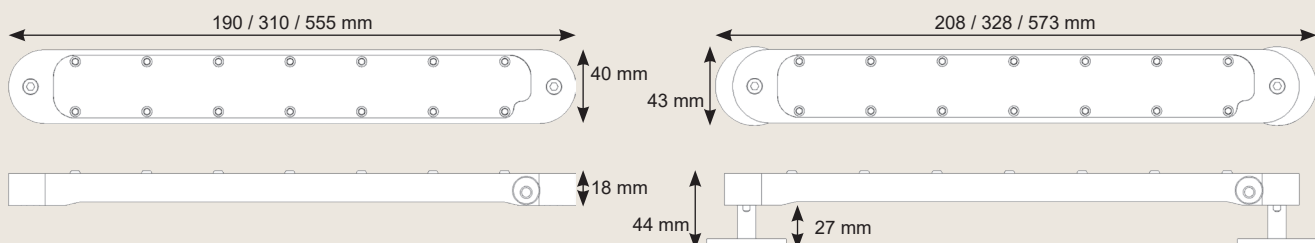

- other versions on request / subject to change and error -